



Standard Test Method for Determination of Oxygenates, Benzene, Toluene, C₈–C₁₂ Aromatics and Total Aromatics in Finished Gasoline by Gas Chromatography/Fourier Transform Infrared Spectroscopy¹

This standard is issued under the fixed designation D 5986; the number immediately following the designation indicates the year of original adoption or, in the case of revision, the year of last revision. A number in parentheses indicates the year of last reapproval. A superscript epsilon (ε) indicates an editorial change since the last revision or reapproval.

1. Scope

1.1 This test method covers the quantitative determination of oxygenates: methyl-t-butylether (MTBE), di-*isopropyl* ether (DIPE), ethyl-t-butylether (ETBE), t-amylmethyl ether (TAME), methanol (MeOH), ethanol (EtOH), 2-propanol (2-PrOH), t-butanol (t-BuOH), 1-propanol (1-PrOH), 2-butanol (2-BuOH), i-butanol (i-BuOH), 1-butanol (1-BuOH); benzene, toluene and C₈–C₁₂ aromatics, and total aromatics in finished motor gasoline by gas chromatography/Fourier Transform infrared spectroscopy (GC/FTIR).

1.2 This test method covers the following concentration ranges: 0.1–20 volume % per component for ethers and alcohols; 0.1–2 volume % benzene; 1–15 volume % for toluene, 10–40 volume % total (C₆–C₁₂) aromatics.

1.3 The method has not been tested by ASTM for refinery individual hydrocarbon process streams, such as reformates, fluid catalytic cracking naphthas, etc., used in blending of gasolines.

1.4 SI units of measurement are preferred and used throughout this test method.

1.5 *This standard does not purport to address all of the safety concerns, if any, associated with its use. It is the responsibility of the user of this standard to establish appropriate safety and health practices and determine the applicability of regulatory limitations prior to use.*

2. Referenced Documents

2.1 *ASTM Standards:*²

D 1298 Test Method for Density, Relative Density (Specific Gravity), or API Gravity of Crude Petroleum and Liquid Petroleum Products by Hydrometer Method

D 4052 Test Method for Density and Relative Density of Liquids by Digital Density Meter

D 4057 Practice for Manual Sampling of Petroleum and Petroleum Products

D 4307 Practice for Preparation of Liquid Blends for Use as Analytical Standards

3. Terminology

3.1 *Definitions of Terms Specific to This Standard:*

3.1.1 *aromatics*—refers to any organic compound containing a benzene or naphthalene ring.

3.1.2 *calibrated aromatic component*—*in this test method*, refers to the individual aromatic components which have a specific calibration.

3.1.3 *cool on-column injector*—*in gas chromatography*, a direct sample introduction system which is set at a temperature at or below the boiling point of solutes or solvent on injection and then heated at a rate equal to or greater than the column. Normally used to eliminate boiling point discrimination on injection or to reduce adsorption, or both, on glass liners within injectors. The sample is injected directly into the head of the capillary column tubing or retention gap.

3.1.4 *Gram-Schmidt chromatogram*—a nonselective summation of total intensity from a spectral scan per unit time which resembles in profile a flame ionization detector chromatogram.

3.1.5 *retention gap*—*in gas chromatography*, refers to a deactivated precolumn which acts as a zone of low retention power for reconcentrating bands in space. The polarity of the precolumn must be similar to that of the analytical column.

3.1.6 *selective wavelength chromatogram (SWC)*—*in this test method*, refers to a selective chromatogram obtained by summing the spectral intensity in a narrow spectral wavelength or frequency range as a function of elution time which is unique to the compound being quantitated.

3.1.7 *uncalibrated aromatic component*—*in this test method*, refers to individual aromatics for which a calibration is not available and whose concentrations are estimated from the response factor of a calibrated aromatic component.

¹ This test method is under the jurisdiction of ASTM Committee D02 on Petroleum Products and Lubricants and is the direct responsibility of Subcommittee D02.04.0L on Gas Chromatography Methods.

Current edition approved Nov. 1, 2006. Published January 2007. Originally approved in 1996. Last previous edition approved in 2001 as D 5986 – 96 (2001).

² For referenced ASTM standards, visit the ASTM website, www.astm.org, or contact ASTM Customer Service at service@astm.org. For *Annual Book of ASTM Standards* volume information, refer to the standard's Document Summary page on the ASTM website.

3.1.8 *wall coated open tubular (WCOT)*—a type of capillary column prepared by coating or bonding the inside wall of the capillary with a thin film of stationary phase.

4. Summary of Test Method

4.1 A gas chromatograph equipped with a methylsilicone WCOT column is interfaced to a Fourier transform infrared spectrometer. The sample is injected through a cool on-column injector capable of injecting a small sample size without overloading the column.

4.2 Calibration is performed using mixtures of specified pure oxygenates and aromatic hydrocarbons on a mass basis. Volume % data is calculated from the densities of the individual components and the density of the sample. Multipoint calibrations consisting of at least five levels and bracketing the concentration of the specified individual aromatics is required. Unidentified aromatic hydrocarbons present which have not been specifically calibrated for are quantitated using the response factor of 1,2,3,5-tetramethylbenzene and summed with the other calibrated aromatic components to obtain a total aromatic concentration of the sample.

4.3 Specified quality control mixture(s) are analyzed to monitor the performance of the calibrated GC/FTIR system.

5. Significance and Use

5.1 Test methods to determine oxygenates, benzene, and the aromatic content of gasoline are necessary to assess product quality and to meet new fuel regulations.

5.2 This test method can be used for gasolines that contain oxygenates (alcohols and ethers) as additives. It has been determined that the common oxygenates found in finished gasoline do not interfere with the analysis of benzene and other aromatics by this test method.

6. Apparatus

6.1 Gas Chromatograph:

6.1.1 System equipped with temperature programmable gas chromatograph suitable for cool-on-column injections. The injector must allow the introduction of small (for example, 0.1 μL) sample sizes at the head of the WCOT column or a retention gap. An autosampler is mandatory.

6.1.2 WCOT column containing a methylsilicone stationary phase which elutes the aromatic hydrocarbons according to their boiling points. A column containing a relatively thick film of stationary phase, such as 4 to 5 μm , is recommended to prevent column sample overload.

6.2 FTIR Spectrometer:

6.2.1 This test method requires a light-pipe GC/FTIR system (Fig. 1). No data have been acquired with matrix-isolation or other deposition type systems.

6.2.2 The spectrometer must be equipped with a mercury-cadmium-telluride (MCT) detector capable of detecting from at least 4000 cm^{-1} to 550 cm^{-1} .

6.2.3 The lower limit of 550 cm^{-1} is necessary for the accurate determination of benzene. Fig. 2 gives an acceptable infrared spectra of benzene.

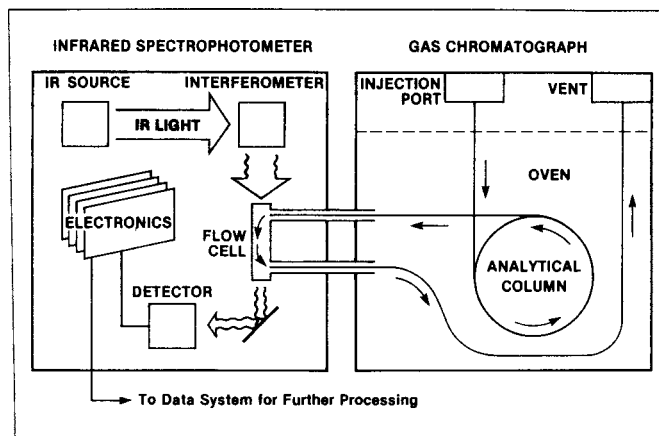

FIG. 1 Light-Pipe GC/FTIR System

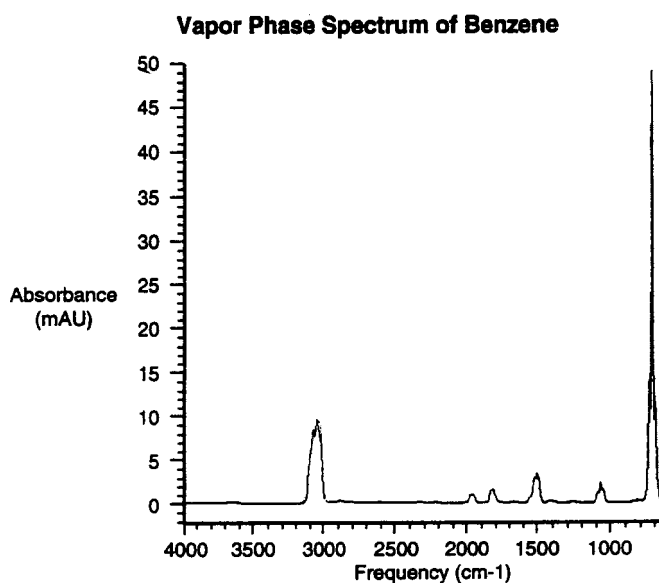

FIG. 2 Vapor Phase Spectrum of Benzene

7. Reagents and Materials

7.1 *Carrier Gas*—Helium and hydrogen have been used successfully. The minimum purity of the carrier gas used must be 99.85 mole %. Additional purification using commercially available scrubbing reagents is recommended to remove trace oxygen which may deteriorate the performance of the GC WCOT column.

7.2 *Dilution Solvents*—*n*-heptane and methylbenzene (toluene) used as a solvent in the preparation of the calibration mixture. Reagent grade. All at 99 % or greater purity. Free from detectable oxygenates and aromatics which may interfere with the analysis.

7.2.1 Toluene should be used as a solvent only for the preparation of C_9 + components and must be free from interfering aromatics. (**Warning**—The gasoline samples and solvents used as reagents such as heptane and toluene are flammable and may be harmful or fatal if ingested or inhaled. Benzene is a known carcinogen. Use with proper ventilation. Safety glasses and gloves are required while preparing samples and standards.)

7.3 *Internal Standard*—1,2-dimethoxyethane (DME) or deuterated compounds, or both, have been used successfully. A single internal standard such as DME may be used. If other internal standards are used, a narrow selective wavelength range must be determined to generate a SWC which yields no interference from other components in the sample.

7.4 *Liquid Nitrogen*, supplied from low pressure dewar. Required for cooling of the MCT detector. Dewar may be connected through an electronic solenoid to the MCT cooling reservoir for unattended operation. (**Warning**—Helium and hydrogen are supplied under high pressure. Hydrogen can be explosive and requires special handling. Hydrogen monitors that automatically shut off supply to the GC in case of serious leaks are available from GC supply manufacturers.)

7.5 *Spectrometer Purge Gas*, N₂ dry air has not been tested, but should be adequate.

NOTE 1—The FTIR spectrometer can be protected by installing appropriate filters to remove volatile oils or contaminants that may be present in commercial low quality nitrogen supplies. A liquid nitrogen dewar may be used as a source for the nitrogen purge.

7.6 *Standards for Calibration and Identification*, all at 99 % or greater purity (Table 1 and Table 2). If reagents of high purity are not available, an accurate assay of the reagent must be performed using a properly calibrated GC or other techniques. The concentration of the impurities which overlap the other calibration components must be known and used to correct the concentration of the calibration components. Because of the error that may be introduced from impurity corrections, the use of only high purity reagents is strongly recommended. Standards are used for calibration as well for establishing the identification by retention time in conjunction with spectral match.

8. Sampling

8.1 Make every effort to ensure that the sample is representative of the fuel source from which it is taken. Follow the recommendations of Practice D 4057 or its equivalent when obtaining samples from bulk storage or pipelines. Sampling to meet certain regulatory specifications may require the use of specific sampling procedures. Consult appropriate regulations.

8.2 Take appropriate steps to minimize the loss of light hydrocarbons from the gasoline sample while sampling and during analyses. Upon receipt in the laboratory chill the sample in its original container to 0 to 5°C (32 to 40°F) before and after a sample is obtained for analysis.

TABLE 1 GC/FTIR Oxygenates Calibration Components

Compound	CAS
Methyl-t-butyl ether (MTBE)	1634-04-4
Ethyl-t-butyl ether (ETBE)	637-92-3
Methyl-t-amyl ether (TAME)	994-05-8
Di-isopropyl ether (DIPE)	108-20-3
Methanol	67-56-1
Ethanol	64-17-5
2-Propanol	67-63-0
t-Butanol	75-65-0
1-Propanol	71-23-6
2-Butanol	15892-23-6
Isobutanol	78-83-1
1-Butanol	71-36-3
1,2-dimethoxyethane (DME) (Internal Standard)	110-71-4

TABLE 2 GC/FTIR Aromatic Hydrocarbons Calibration Components (Calibrated Aromatic Components)

Compound	CAS No.
Benzene	71-43-2
Methylbenzene	108-88-3
Ethylbenzene	100-41-4
1,3-Dimethylbenzene	108-38-3
1,4-Dimethylbenzene	106-42-3
1,2-Dimethylbenzene	95-47-6
(1-Methylethyl)-benzene	98-82-8
Propyl-benzene	103-65-1
1-methyl-3-ethylbenzene	620-14-4
1-methyl-4-ethylbenzene	622-96-8
1,3,5-trimethylbenzene	108-67-8
1-methyl-2-ethylbenzene	611-14-3
1,2,4-trimethylbenzene	95-63-6
1,2,3-trimethylbenzene	526-73-8
Indan	496-11-7
1,4-diethylbenzene	105-05-5
Butylbenzene	104-51-8
1,2-Diethylbenzene	135-01-3
1,2,4,5-Tetramethylbenzene	95-93-2
1,2,3,5-Tetramethylbenzene	527-53-7
Naphthalene	91-20-3
2-methyl-naphthalene	91-57-6
1-methyl-naphthalene	90-12-0

8.3 After the sample is prepared for analysis with internal standard(s), chill the sample and transfer to an appropriate autosampler vial with minimal headspace. Re-chill the remainder of the sample immediately and protect from evaporation for further analyses, if necessary.

9. Calibration Procedure

9.1 *Preparation of Calibration Standards*—Prepare multi-component calibration standards using the compounds listed in Table 1 and Table 2 by mass according to Practice D 4307. Prepare calibration solutions as described in 9.1-9.1.4 for each set. Adjust these concentrations, as necessary, to ensure that the concentrations of the components in the actual samples are bracketed by the calibration concentrations. Solid components are weighed directly into the flask or vial. The specified volumes of each calibration component are weighed into 100 mL volumetric flasks or 100 mL septum capped vials. Prepare a calibration standard as follows. Cap and record the tare weight of the 100 mL volumetric flask or vial to 0.1 mg. Remove the cap and carefully add components to the flask or vial starting with the least volatile component. Cap the flask and record the net mass (*W_i*) of the aromatic component added to 0.1 mg. Repeat the addition and weighing procedure for each component. Similarly add the internal standard and record its net mass (*W_s*) to 0.1 mg. Store the capped calibration standards in a refrigerator at 0 to 5°C (32 to 40°F) when not in use.

NOTE 2—Mix all calibration solutions for at least 30 s on a Vortex mixer after preparation or equivalent. Highly precise sample robotic sample preparation systems are available commercially. These systems may be used provided that the results for the quality control reference material (Section 11) are met when prepared in this manner.

9.1.1 Ethers and Alcohols:

9.1.1.1 Three sets of at least six calibration levels each (eighteen total solutions) are prepared bracketing the 0 to 20 volume % range. *Set 1*: for MTBE, DIPE, ETBE, TAME; *Set*